

FANLAB

PRODUCT SPECIFICATION

Customer: _____

Name : _____

Model: FL-EC630V-T400-13760-G

Version: V0

Edit: _____

Auditing: _____

Approval: _____

2024-01-31

FANLAB

General

This specification defines the general data, mechanical, electrical characteristics, environment and experiment, performance curve, Outline Drawing and precautions of the EC external rotor axial fan and so on.

Standard:

GB 12350-2009 《Safety requirements of small power motors》

GB/T 21418-2008 《General specification for permanent magnet brushless motor system》

JB/T 10562-2006 《Technical specification for general purposes axial fans》

General Data

No.	Name	Parameter
2.1	Max Air Flow	11600m ³ /h
2.2	Rated Speed	1000r/min
2.3	Input Power	720W
2.4	Rated Voltage	400V
2.5	Operating Voltage	380-480 VAC
2.6	Start Voltage	/
2.7	Rated Current	≤1.5A
2.8	Noise Level	71±5dB(A)
2.9	Direction	CW(seen on rotor of motor)
2.10	Insulation Class	F
2.11	Speed Control	0~10VDC & PWM
2.12	Grounding Resistance	≤0.1 Ω
2.13	Withstand voltage	Voltage:1500VAC 50Hz Tripping current:10mA Time: 60 s
2.14	Insulation Resistance	Voltage:500VDC Resistance: ≥50M Ω

FANLAB

No.	Name	Parameter
2.15	Electrical Protection	Undervoltage protection Overvoltage protection Overcurrent protection Locked rotor protection Automatic restart capability Soft start
2.16	IP Class	IP54
2.17	Signal Feedback	FG sign:open-drain output, 1 pulses/R
2.18	Voltage output	+10VDC
2.19	RoHS	All the material meets RoHS standard.
2.20	Impeller Color	Black
2.21	Bearing	Deep groove ball bearings
2.22	Weight	15.8Kg
2.23	Package	Carton+ pallet
2.24	Operating Temperature	-25°C to 60°C
2.25	Operating Humidity	5% to 90% RH
2.26	Lead Wire	4×0.75mm ² ,RV90, L= 1.5m
2.27	Control wire	4×0.50mm ² ,RV90, L= 1.5m
2.28	Material of Blades	SPCC
2.29	Material of Mesh Enclosure	Q195

FANLAB

Performance curve and Rating plate

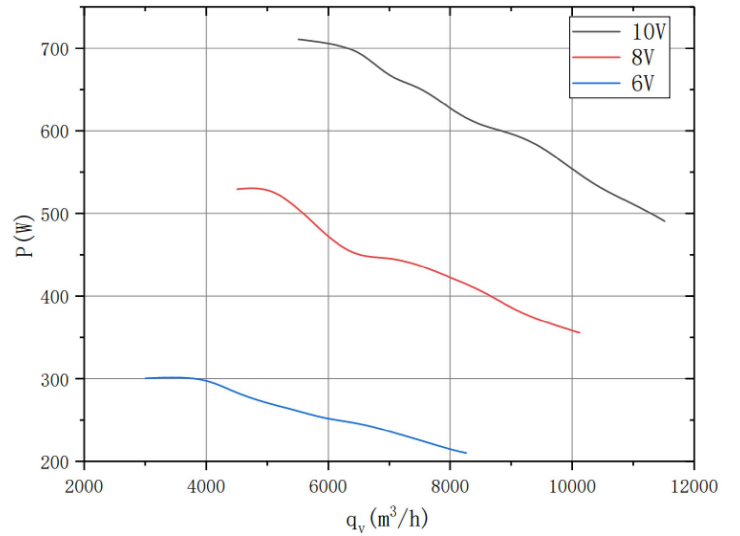
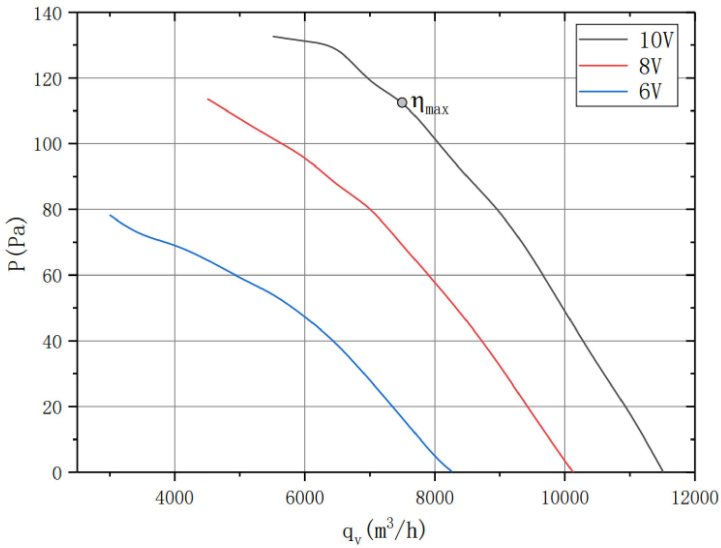

FANLAB	FL-EC630V-T400-13760-G	
400V 50/60Hz 615/720W 1000r/min CL.F IP54		
Erp2015(N40) N=46.8 η _{statA} =39.3%		CE
Blk:L1 Bro:L2 Blu:L3 Yel:Gre:PE		
Red:+10V Blu:GND Whi:Tach output Yel:0~10VDC/PWM	xx/xx	

Outline Drawing

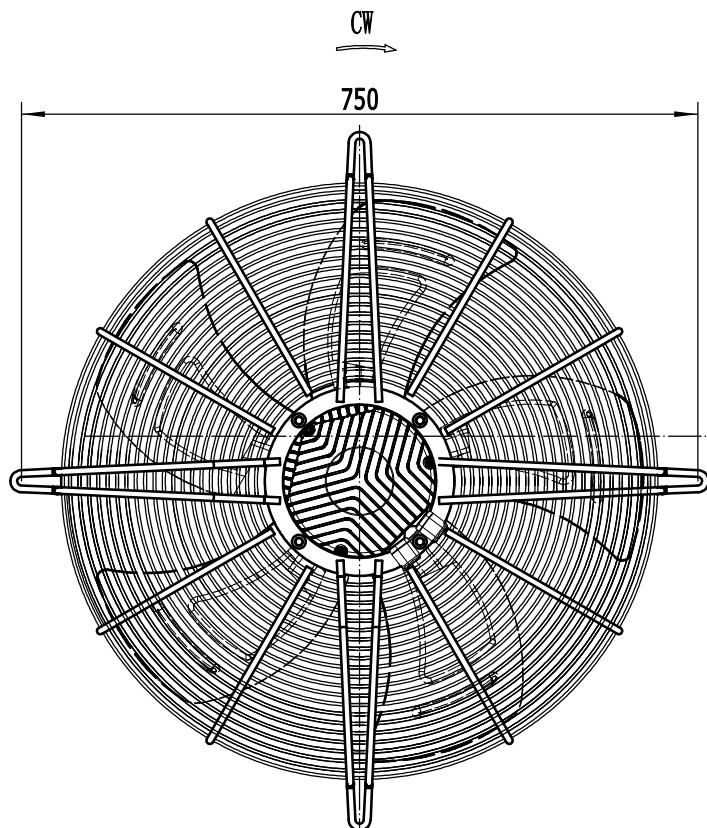
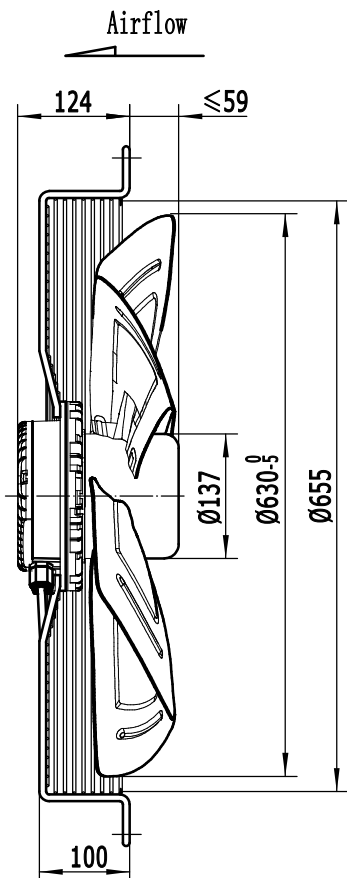

FANLAB

Connection Diagram

(1). Motor connection diagram:

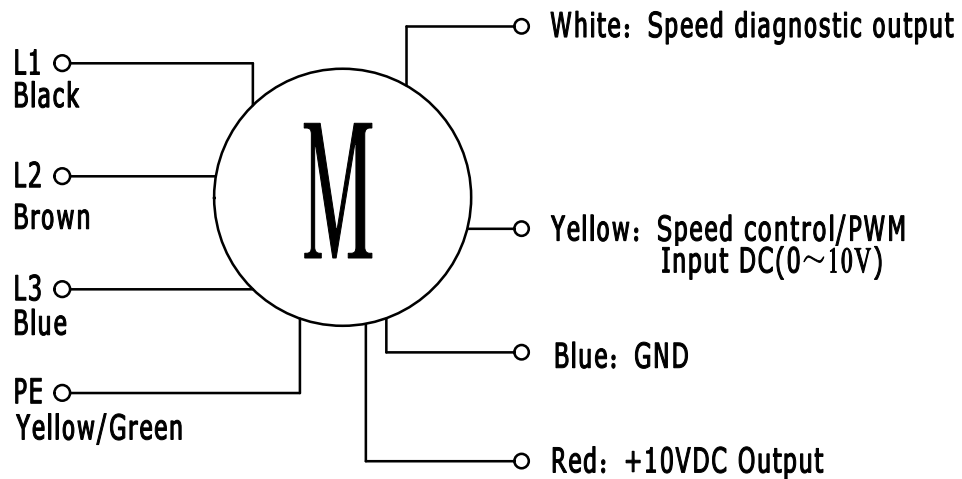

(2). Interface Circuit:

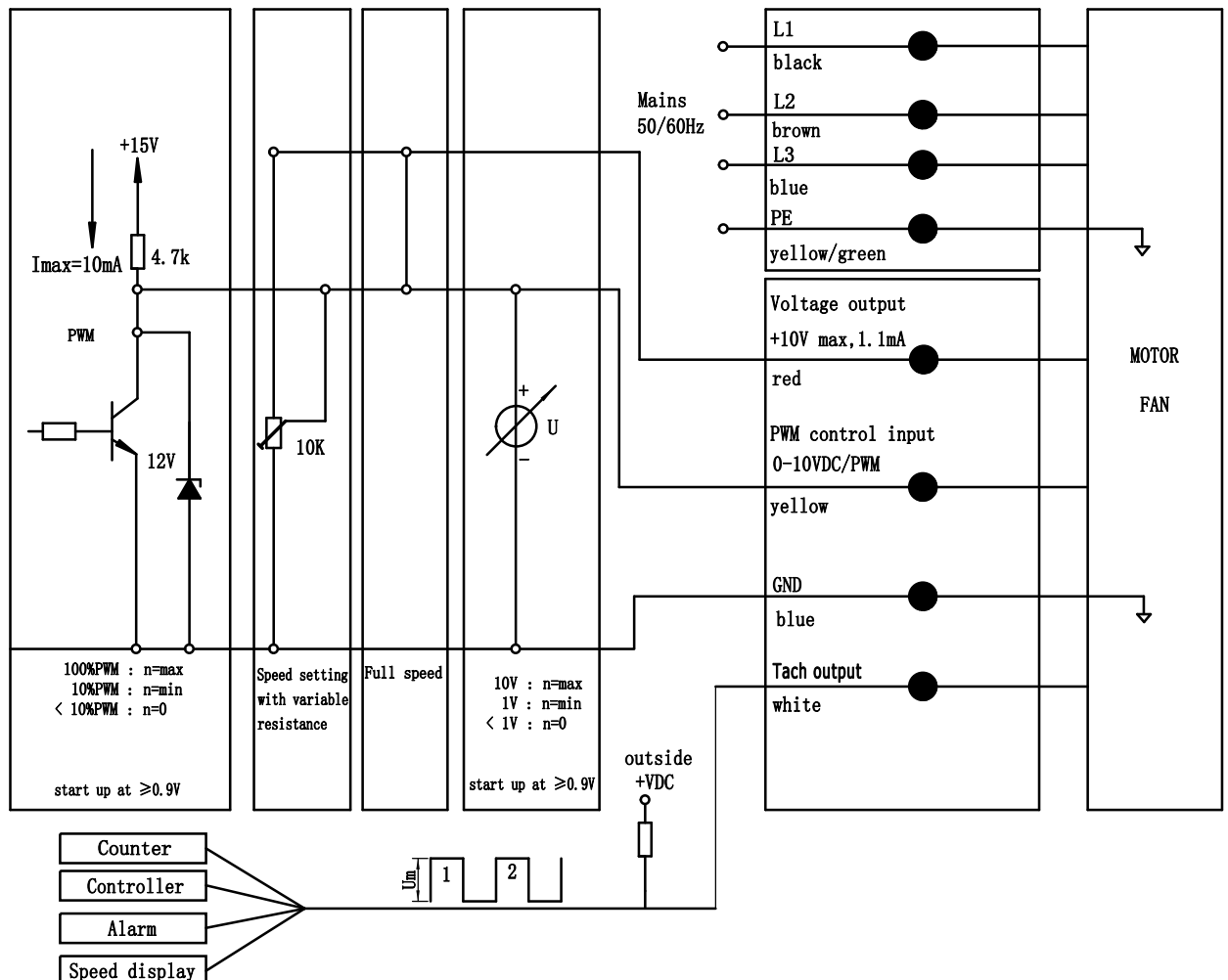

FANLAB

(3). FG signal connection diagram:

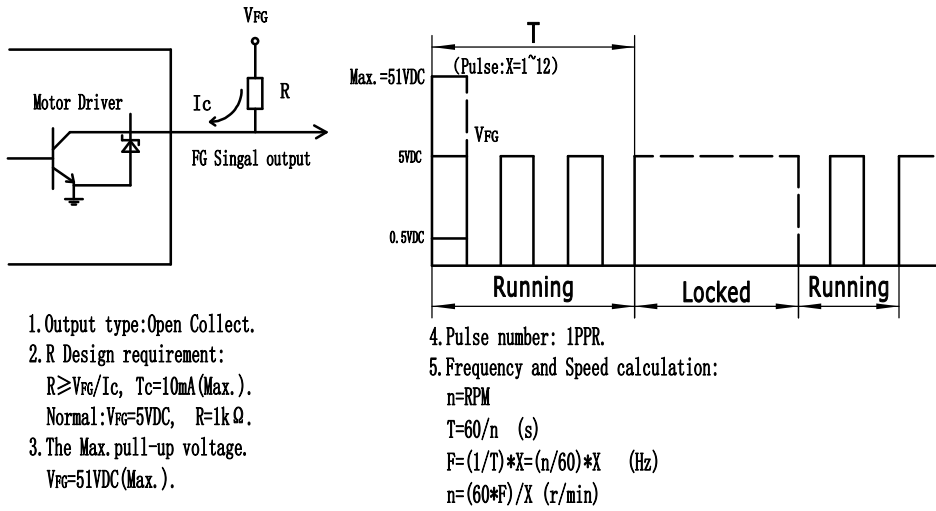

(4). Control Characteristics:

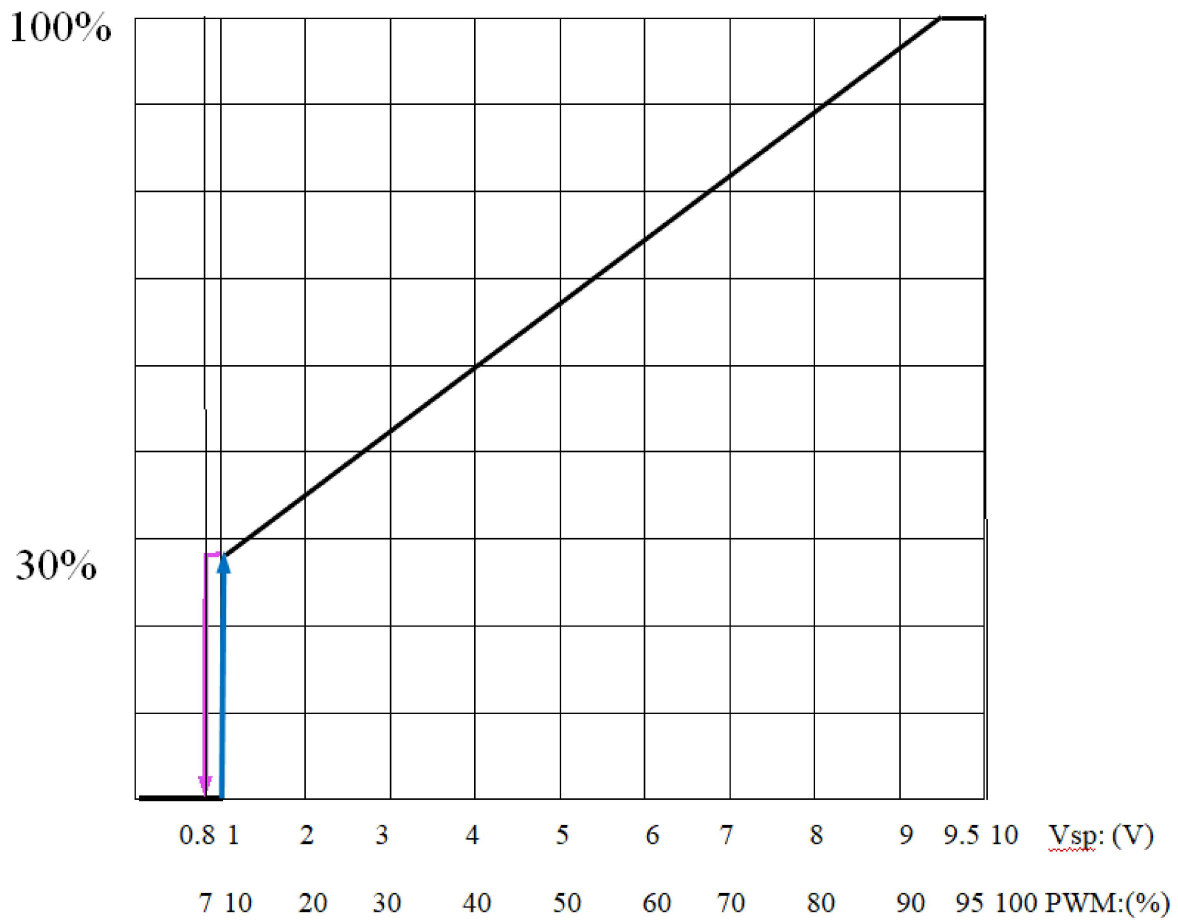

FANLAB

Precautions

- 1、 The fan can be operate after the yellow and green wire of the fan connecting the ground effective, High risk, to prevent grounding caused by electric shock or not affected operation.
- 2、 The red, black, white, yellow, green lines of the fan are not allowed to access the high voltage ac power supply, to prevent burn out the fan.
- 3、 Green line prohibits direct connection red + 10 VDC or external dc power supply voltage output line. You need to connect an external resistor when you want the Square wave speed signal output. Details see the connecting screen.
- 4、 Fan may need to wait for a few seconds after the power supply to start running, ban after electrify immediately touch wind turbines or touch under low speed wind turbines, to prevent personal injury.
- 5、 Please read carefully the "technical specification before use the product ".