

# FANLAB

---

## PRODUCT SPECIFICATION

Customer: \_\_\_\_\_

Name : \_\_\_\_\_

Model: FL-EC250A-230-35S1-01-G \_\_\_\_\_

Version: V2 \_\_\_\_\_

Edit: \_\_\_\_\_

Auditing: \_\_\_\_\_

Approval: \_\_\_\_\_

---

2023-05-27

# FANLAB

---

## General

This specification defines the general data, mechanical, electrical characteristics, environment and experiment, performance curve, Outline Drawing and precautions of the EC external rotor axial fan and so on.

Standard:

GB 12350-2022 《Safety requirements of small power motors》

GB/T 21418-2008 《General specification for permanent magnet brushless motor system》

JB/T 10562-2006 《Technical specification for general purposes axial fans》

## General Data

No.	Name	Parameter
2.1	Max Air Flow	2100 m <sup>3</sup> /h
2.2	Rated Speed	3000 r/min
2.3	Input Power	160W
2.4	Rated Voltage	230V
2.5	Operating Voltage	200-277 VAC
2.6	Start Voltage	≤199VAC
2.7	Rated Current	≤1.2A
2.8	Noise Level	≤79dB(A)
2.9	Direction	CCW(seen on rotor of motor)
2.10	Insulation Class	F
2.11	Speed Control	0~10VDC & PWM
2.12	Grounding Resistance	≤0.1 Ω
2.13	Withstand voltage	Voltage:1500VAC 50Hz Tripping current:10mA Time: 60 s
2.14	Insulation Resistance	Voltage:500VDC Resistance: ≥50M Ω

# FANLAB

---

No.	Name	Parameter
2.15	Electrical Protection	Undervoltage protection Overvoltage protection Overcurrent protection Locked rotor protection Automatic restart capability Soft start
2.16	IP Class	IP54
2.17	Signal Feedback	FG sign:open-drain output, 1 pulses/R
2.18	Voltage output	+10VDC
2.19	RoHS	All the material meets RoHS standard.
2.20	Impeller Color	Black
2.21	Bearing	Deep groove ball bearings
2.22	Weight	2.3Kg
2.23	Package	Carton+ pallet
2.24	Operating Temperature	-25°C to 60°C
2.25	Operating Humidity	5% to 90% RH
2.26	Lead wire	3×0.5mm <sup>2</sup> ,RV90,L=0.6m
2.27	Control wire	4×0.3mm <sup>2</sup> ,RV90,L=0.6m
2.28	Material of blades	SPCC
2.29	Material of the grille	Q195

# FANLAB

## Performance curve and Rating plate

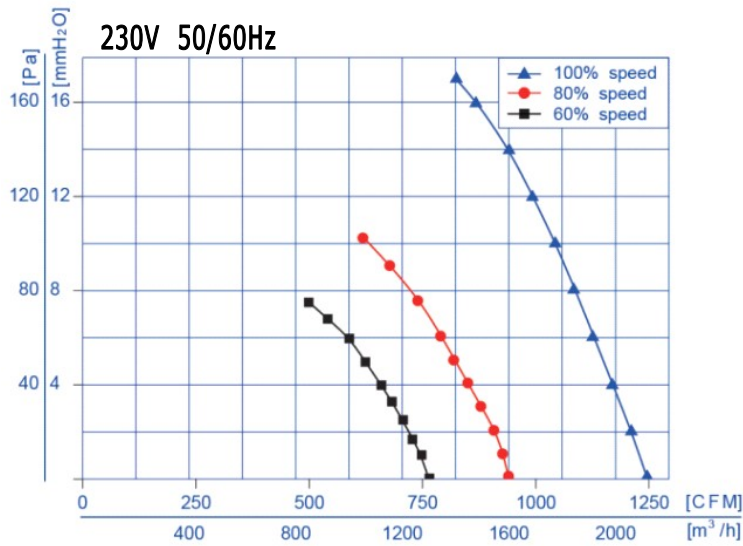

**FANLAB** FL-EC250A-230-35S1-01-G

230V 50/60Hz 123/160W 3000r/min CL.F IP54

Erp2015(N40) N=39  $\eta_{statA}=28.1\%$

Bro:L Blu:N Yel-Gre:PE

Red:+10V Blu:GND Whi:Tach output Yel:0~10VDC/PWM

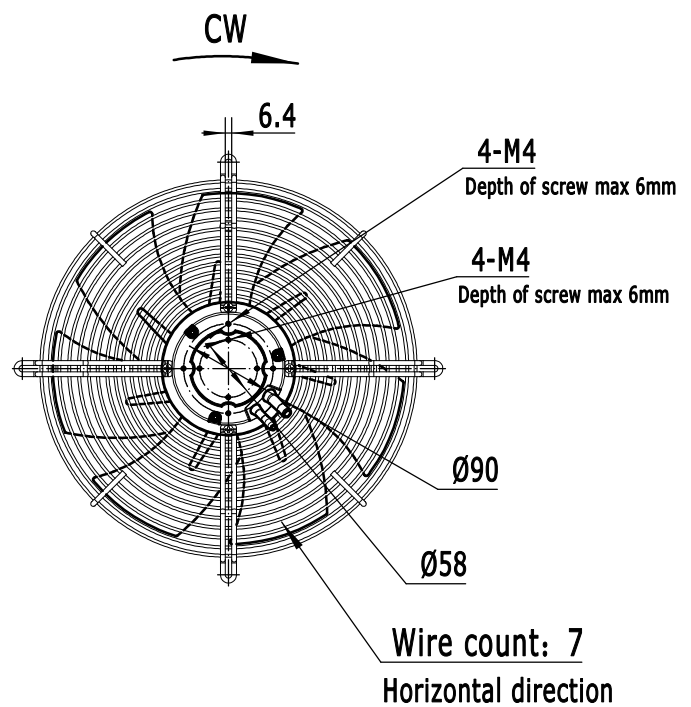
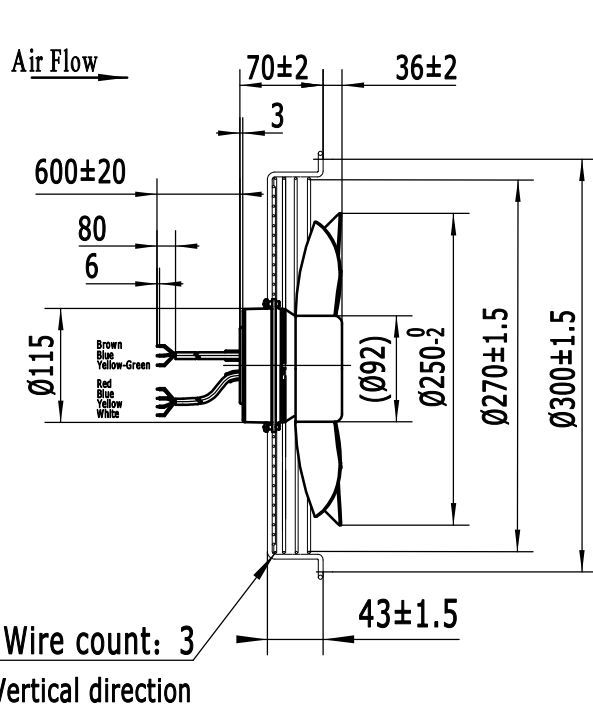

# FANLAB

## Connection Diagram

(1).Motor connection diagram:

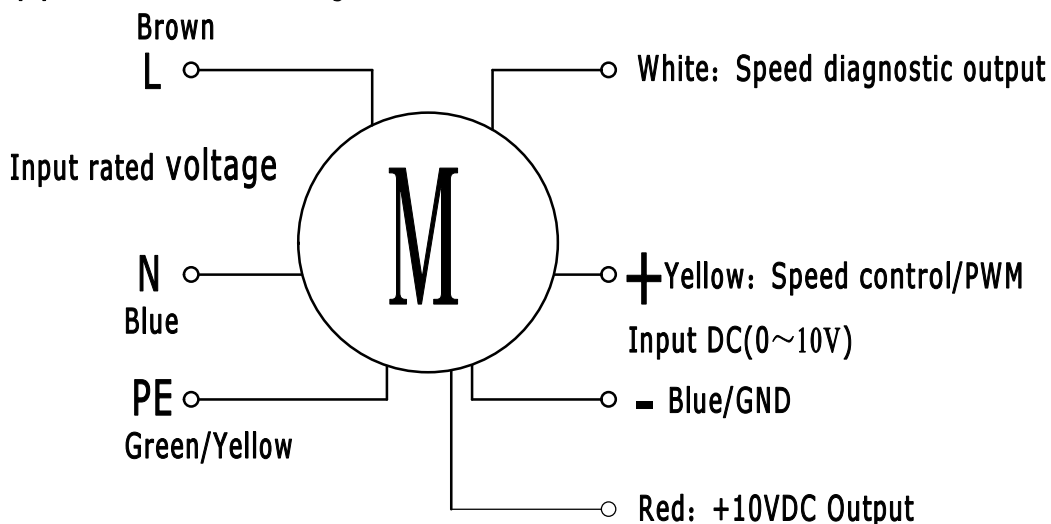

(2).Interface Circuit:

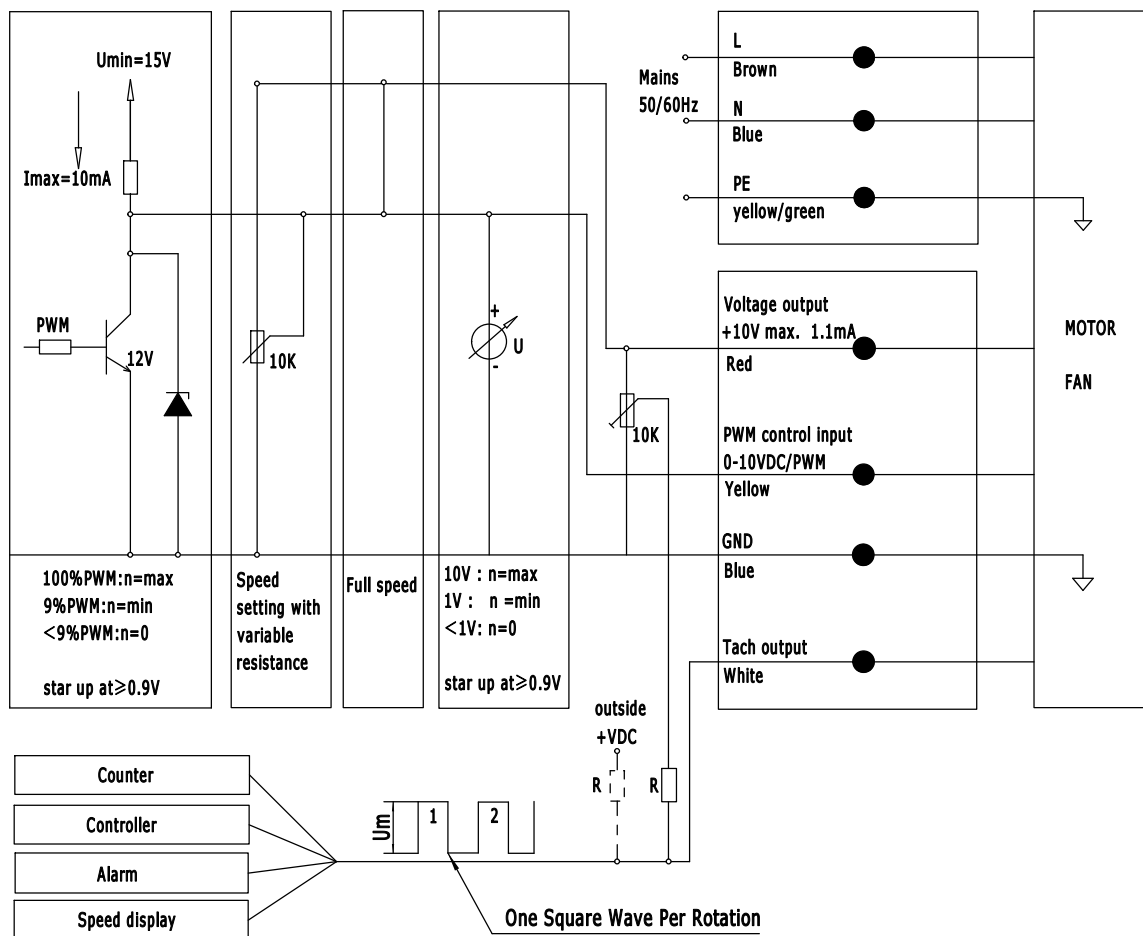

# FANLAB

## (3).FG signal connection diagram:

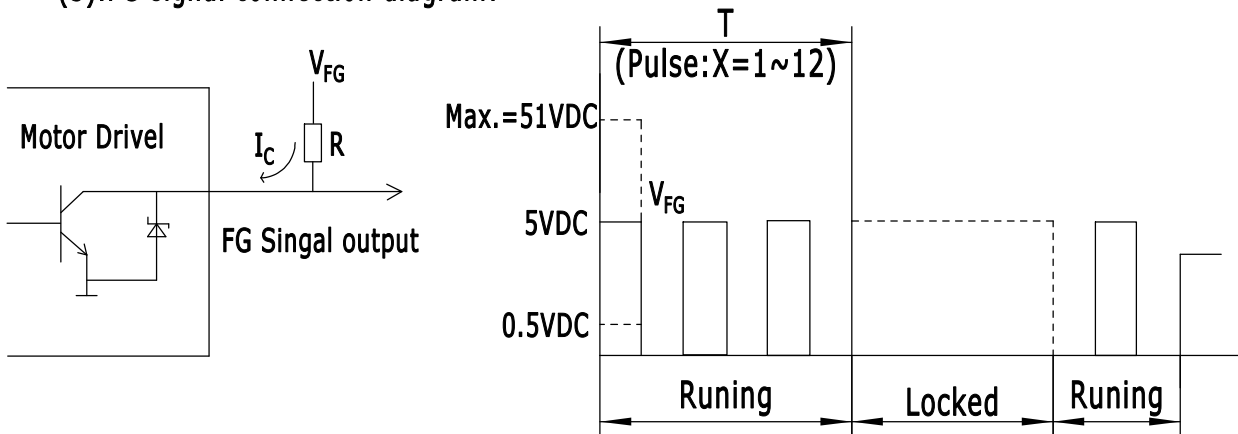

1.Out put type:Open Collect.

2.R Design requirement:

$$R \geq V_{FG}/I_C, T_C=10\text{mA(Max.)}$$

$$\text{Normal: } V_{FG}=5\text{VDC}, R=1\text{k}\Omega$$

3.The Max.pull-up voltage.

$$V_{FG}=51\text{VDC(Max.)}$$

4.Pulse number:10ppr.

5.Frequency and Speed calculation:

$$n=\text{RPM}$$

$$T=60/n \text{ (s)}$$

$$F=(1/T)*X=(n/60)*X \text{ (Hz)}$$

$$n=(60*F)/X \text{ (r/min)}$$

## (3).Speed control signal diagram:

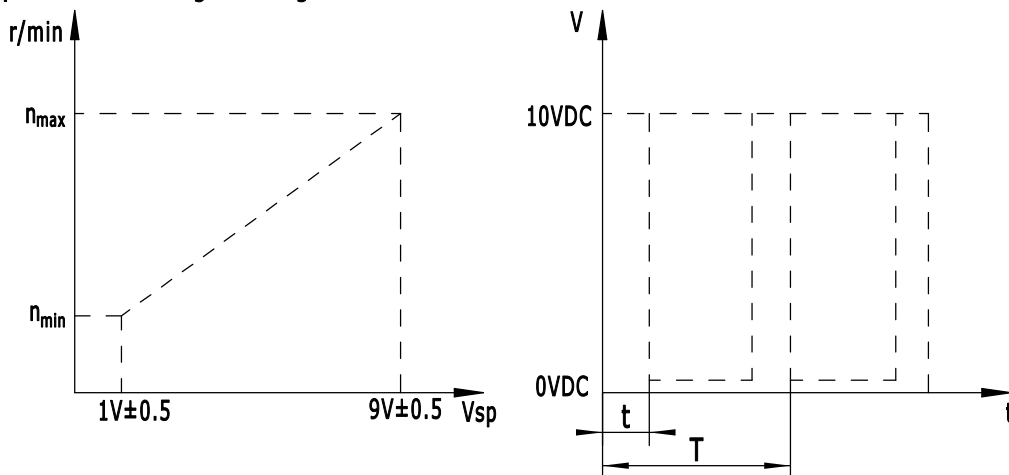

1.The speed control signal of support for 0~10VDC/PWM

2.Only need to full speed, speed wire (Yellow) can be directly connected with +10V (Red).

3.The maximum speed of voltage support up to 65VDC,10VDC or more is running at full speed.

4.When adjust the speed using PWM,The voltage amplitude is 10VDC, adjusting the duty cycle from 0 to 100% for speed adjustment.

# FANLAB

---

## Precautions

- 1、 The fan can be operate after the yellow and green wire of the fan connecting the ground effective, High risk, to prevent grounding caused by electric shock or not affected operation.
- 2、 The red, yellow, blue and white lines of the fan are not allowed to access the high voltage ac power supply, to prevent burn out the fan.
- 3、 White line prohibits direct connection red + 10 VDC or external dc power supply voltage output line.You need to connect an external resistor wen you what the Square wave speed signal output.Details see the connecting screen.
- 4、 Fan may need to wait for a few seconds after the power supply to start running, ban after electrify immediately touch wind turbines or touch under low speed wind turbines, to prevent personal injury.
- 5、 Please read carefully the "technical specification before use the product ".