

# FANLAB

---

## PRODUCT SPECIFICATION

Customer:

Name :

Model: FL-EC500V-230-108P1-01-G

Version: V1

Edit:

Auditing:

Approval:

---

2022-04-25

# FANLAB

---

## General

This specification defines the general data, mechanical, electrical characteristics, environment and experiment, performance curve, Outline Drawing and precautions of the EC external rotor axial fan and so on.

Standard:

GB 12350-2009 《Safety requirements of small power motors》

GB/T 21418-2008 《General specification for permanent magnet brushless motor system》

JB/T 10562-2006 《Technical specification for general purposes axial fans》

## General Data

No.	Name	Parameter
2.1	Max Air Flow	7600m <sup>3</sup> /h
2.2	Rated Speed	1350 r/min
2.3	Input Power	600W
2.4	Rated Voltage	230V
2.5	Operating Voltage	200-277 VAC
2.6	Start Voltage	≤199VAC
2.7	Rated Current	≤2.8A
2.8	Noise Level	74±5dB(A)
2.9	Direction	CCW(seen on rotor of motor)
2.10	Insulation Class	F
2.11	Speed Control	0~10VDC & PWM
2.12	Grounding Resistance	≤0.1 Ω
2.13	Withstand voltage	Voltage:1500VAC 50Hz Tripping current:10mA Time: 60 s
2.14	Insulation Resistance	Voltage:500VDC Resistance: ≥50M Ω

# FANLAB

No.	Name	Parameter
2.15	Electrical Protection	Undervoltage protection Overvoltage protection Overcurrent protection Locked rotor protection Automatic restart capability Soft start
2.16	IP Class	IP54
2.17	Signal Feedback	FG sign:open-drain output, 1 pulses/R
2.18	Voltage output	+10VDC
2.19	RoHS	All the material meets RoHS standard.
2.20	Impeller Color	Black
2.21	Bearing	Deep groove ball bearings
2.22	Weight	10Kg
2.23	Package	Carton+ pallet
2.24	Operating Temperature	-25°C to 60°C
2.25	Operating Humidity	5% to 90% RH
2.26	Lead Wire	3×0.75mm <sup>2</sup> ,RV90, L= 1.5m
2.27	Control wire	4×0.50mm <sup>2</sup> ,RV90, L= 1.5m
2.28	Material of Blades	GFPP-L40 Plastic
2.29	Material of Mesh Enclosure	Q195

# FANLAB

## Performance curve and Rating plate

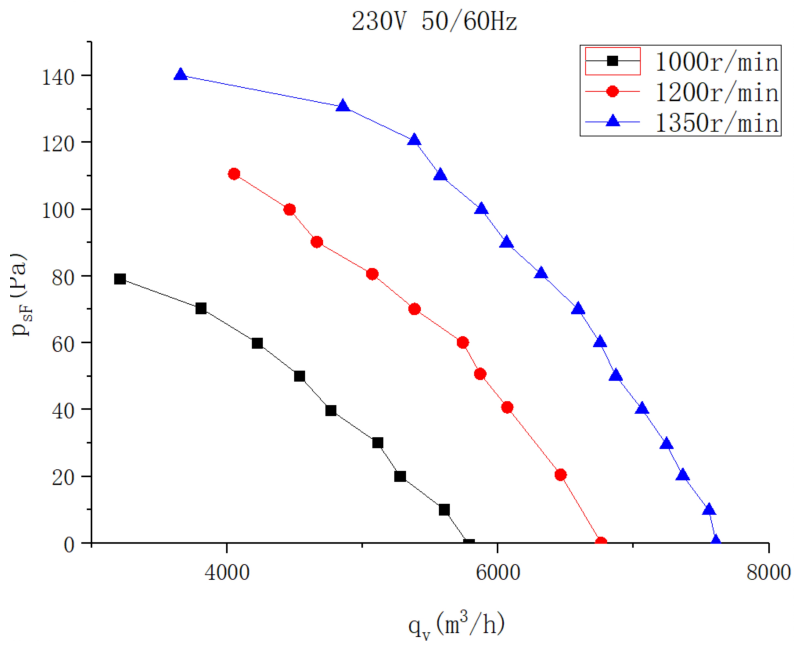

<b>FANLAB</b>	<b>FL-EC500V-230-108P1-01-G</b>
230V 50/60Hz 510/600W 1350r/min CL.F IP54	<b>CE</b>
Erp2015 (N40) N=40.6 $\eta_{statA}=32.9\%$	Week/Year
Bro:L Blu:N Yel-Gre:PE	
Red:+10V Blu:GND Whi:Tach output Yel:0~10VDC/PWM	

## Outline Drawing

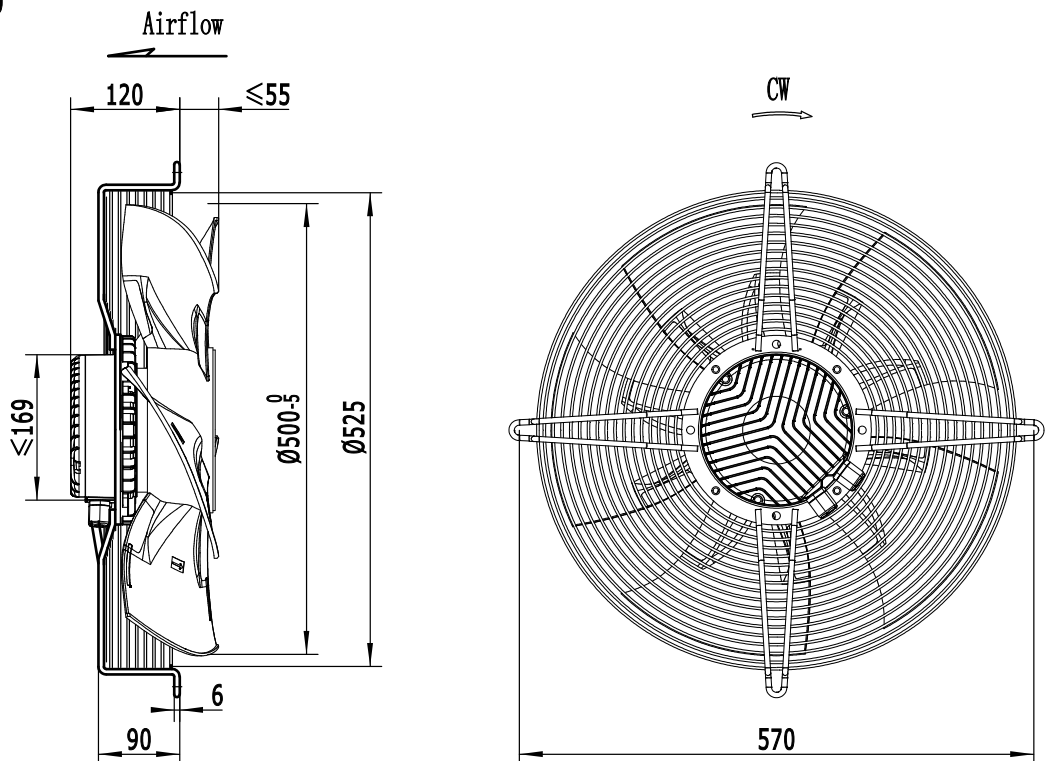

# FANLAB

## Connection Diagram

### (1). Motor connection diagram:

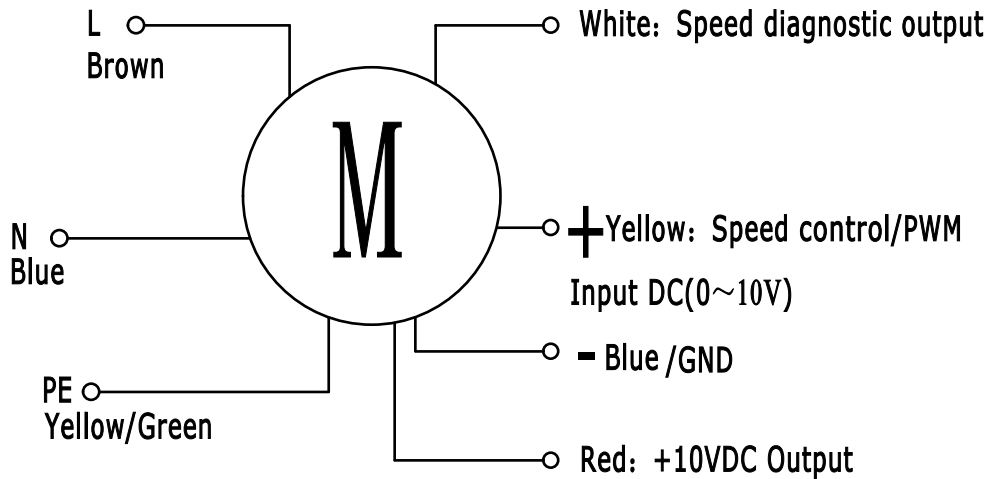

### (2). Interface Circuit:

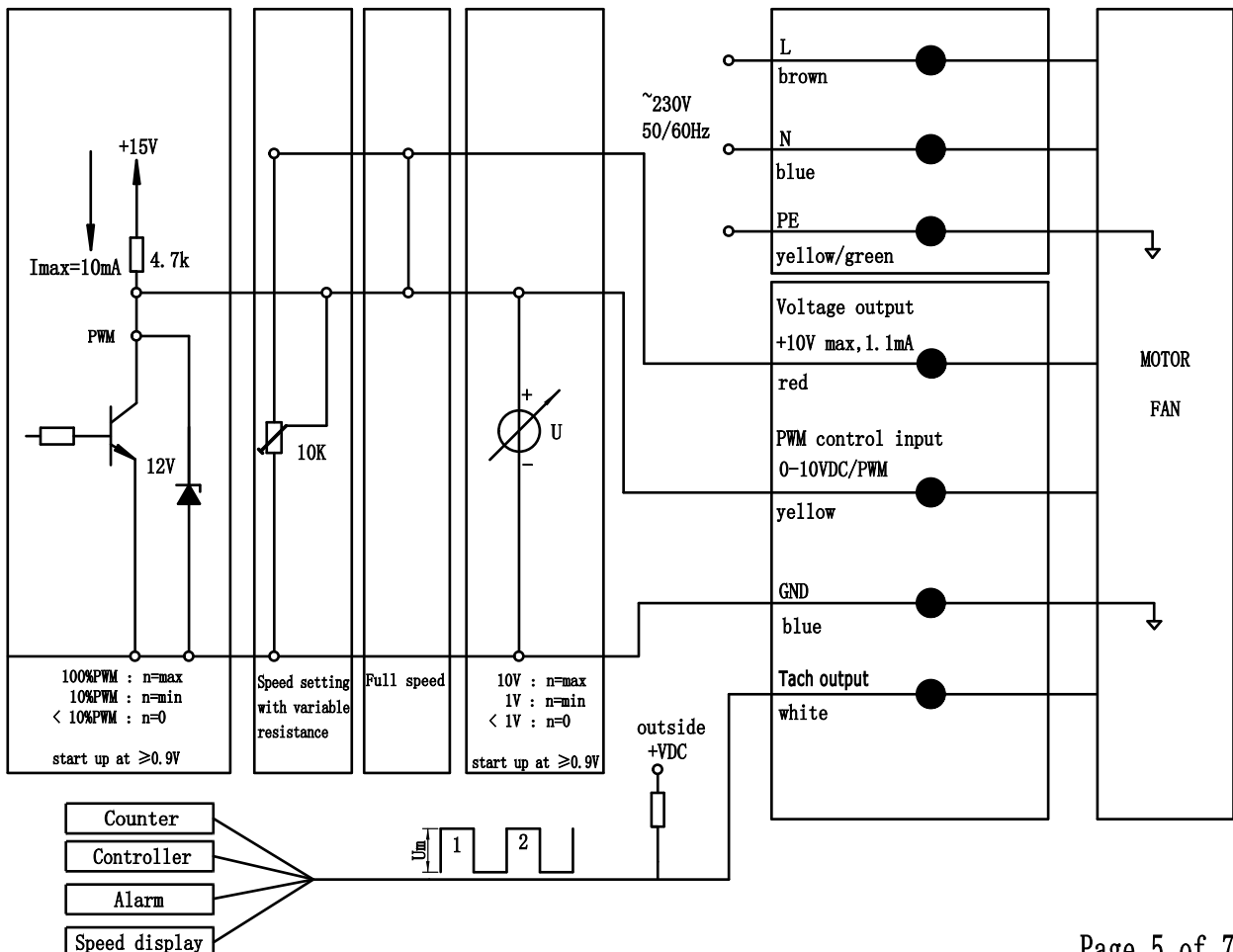

# FANLAB

## (3). FG signal connection diagram:

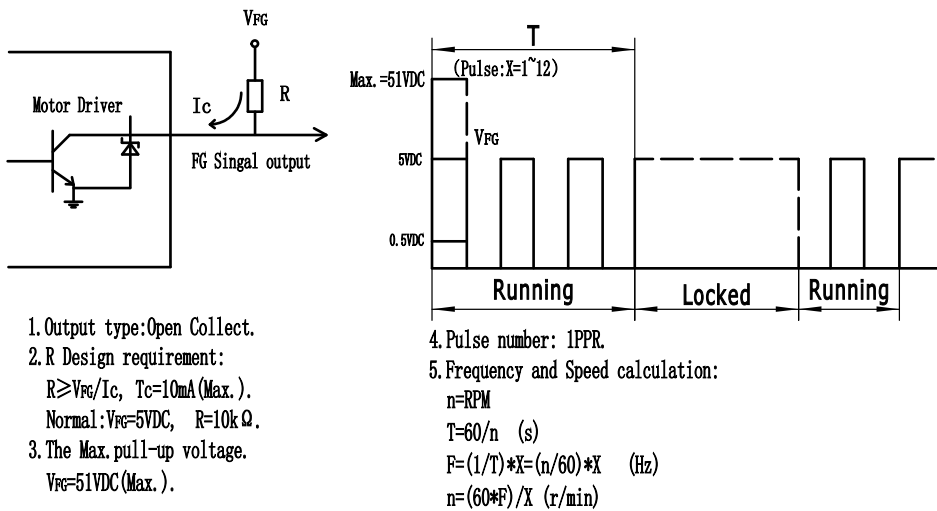

## (4). Speed control signal diagram:

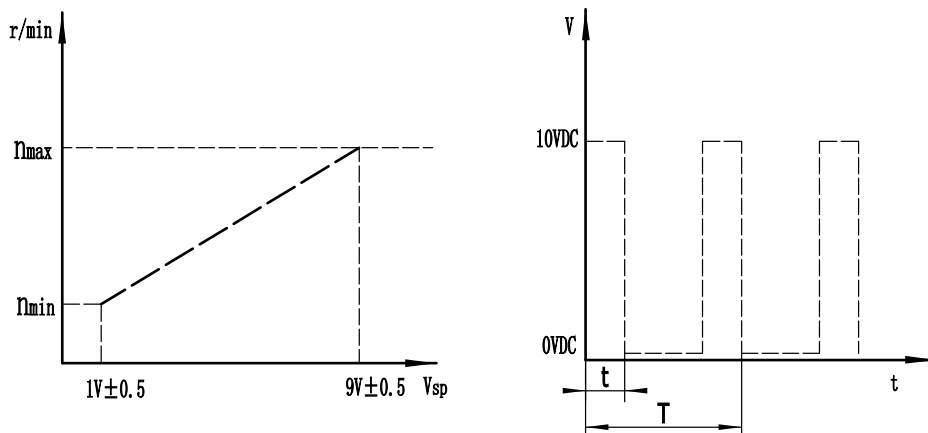

1. The speed control signal: 0~10VDC /PWM
2. At full speed, speed wire can be directly connected with 48VDC or 24VDC or 12VDC or 10VDC direct line.
3. PWM frequency 1~10kHz, duty cycle 0~100%. The speed control signal of support for 0.9~10VDC Analog voltage pulse with PWM compatible.

# FANLAB

---

## Precautions

- 1、 The fan can be operate after the yellow and green wire of the fan connecting the ground effective, High risk, to prevent grounding caused by electric shock or not affected operation.
- 2、 The red, black, white, yellow, green lines of the fan are not allowed to access the high voltage ac power supply, to prevent burn out the fan.
- 3、 Green line prohibits direct connection red + 10 VDC or external dc power supply voltage output line. You need to connect an external resistor when you want the Square wave speed signal output. Details see the connecting screen.
- 4、 Fan may need to wait for a few seconds after the power supply to start running, ban after electrify immediately touch wind turbines or touch under low speed wind turbines, to prevent personal injury.
- 5、 Please read carefully the "technical specification before use the product ".