

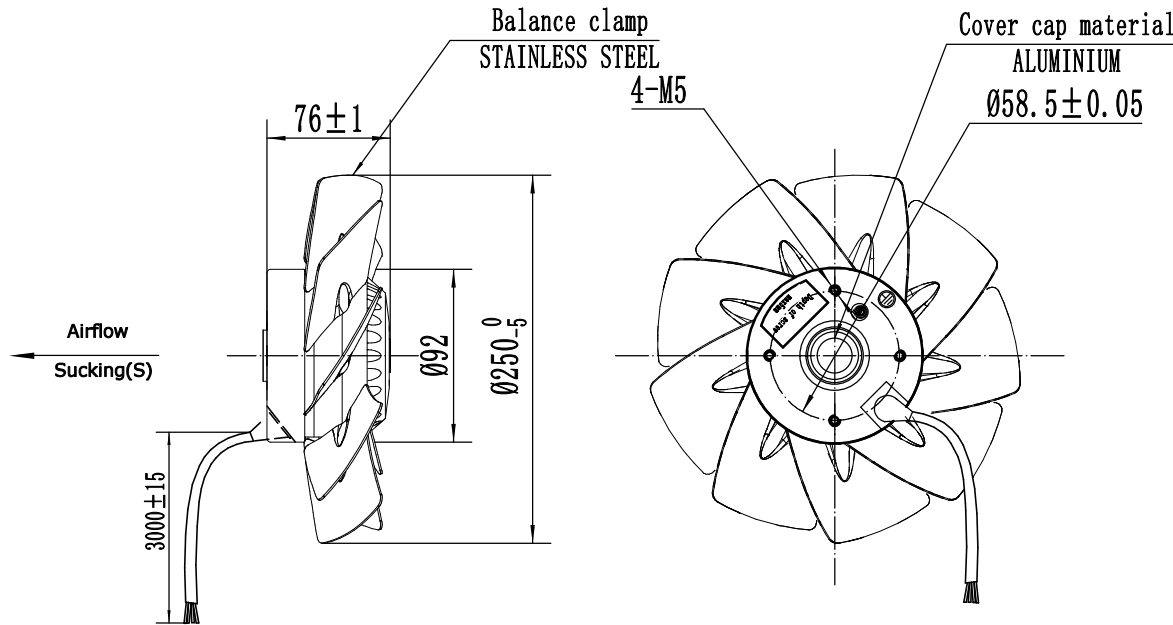

SPECIFICATION



UNIT	Axial fan motor
MOTOR	Single phase motor with capacitor
MOTOR TYPE	FL-2M250V230-S
VOLTAGE (V)	230
FREQUENCY (Hz)	50/60
INPUT POWER (W)	90/110
CURRENT (A)	0.42/0.52
SPEED (r/min)	2400/2400
AIR FLOW 20Pa (m ³ /h)	1389/1588
NOISE (dBA)	60/60
CAPACITOR (μF/450V)	3
ROTATION	CCW ,looking into the end-shield
INSULATION CLASS	F
MOTOR PROTECTION	Thermocontact 150±5°C
TEMPERATURE RISE	75K max
TYPE OF PROTECTION	IP54
OPERATING TYPE	S1
AMBIENT TEMPERATURE	-40°C +60°C
BEARINGS	Ball bearings
MOUNTING TYPE	Horizontal or Vertical
ELECTRICAL CONNECTION	Lead wire RV-90 4G 0.50mm ² ,Length 3000mm
APPROVALS	CE
NET WEIGHT/GROSS WEIGHT	2.0/2.5kg
PACKING	27.0*27.0*11cm
FANS MATERIAL	Stainless steel 304

LABEL :

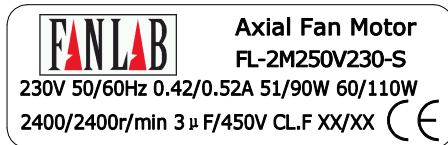

FLOW RATE CURVE:

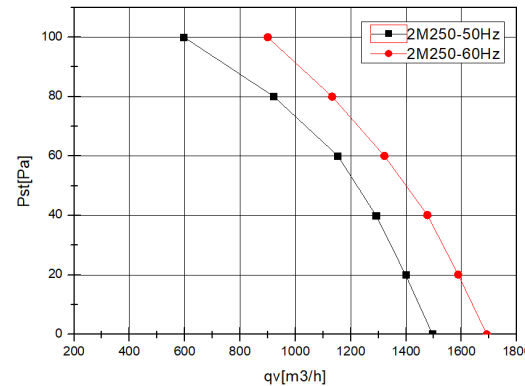

WIRING DIAGRAM:

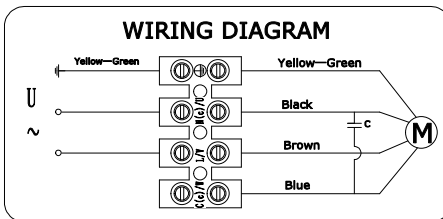

							SIGN	DATE	TITLE
							DRN. BY		FL-2M250V230-S
							CHD. BY		PROJECTION  A4
							ENG. BY		
REV.	DESCRIPTION	APPROVED	DATE				APP. BY		SHEET: of